

# PRODUCT SPECIFICATION

DATE: 02/22/00'

<b>COSMO</b> ELECTRONICS CORPORATION	Magnetic Sensor Set : P1-1A15 P010	NO. 50R00008	REV. 3
		SHEET 1 OF 2	

## 1. OUTSIDE DIMENSION : UNIT ( mm )

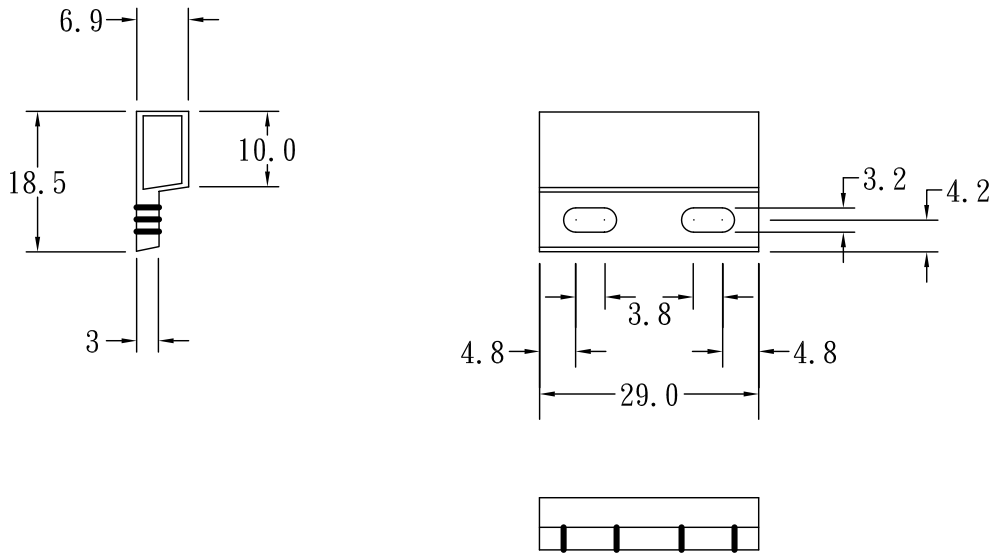

## 2. SCHEMATIC : TOP VIEW

a. ACTUATOR  
P010

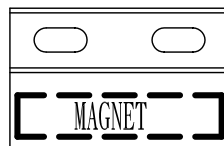

b. SENSOR  
P1-1A15

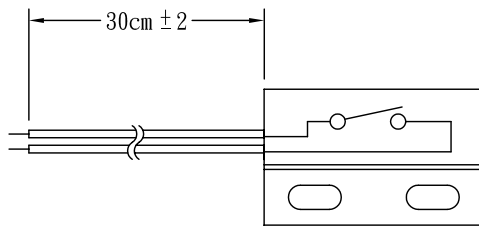

ISSUE	CHECK	APPROVED
-------	-------	----------

# PRODUCT SPECIFICATION

DATE: 02/22/00'

<b>COSMO</b> ELECTRONICS CORPORATION	Magnetic Sensor Set : P1-1A15 P010	NO. 50R00008	REV. 3
		SHEET 2 OF 2	

### 3.0 SPECIFICATIONS:

3.1 Contact Rating	10	VA (max)
3.2 Switching Volatge	200	VDC (max)
3.3 Switching Curren	0.5	A (max)
3.4 Breakdown Voltage (Open Contact)	250	VDC (min)
3.5 Contact Resistance (Initial)	200	mΩ (max)
3.6 Electrical Life (5 VDC, 10 mA)	10 <sup>7</sup>	
3.7 Operating Temp	-40 to 125°C	

### 4.0 OPERATING CHARACTERISTICS:

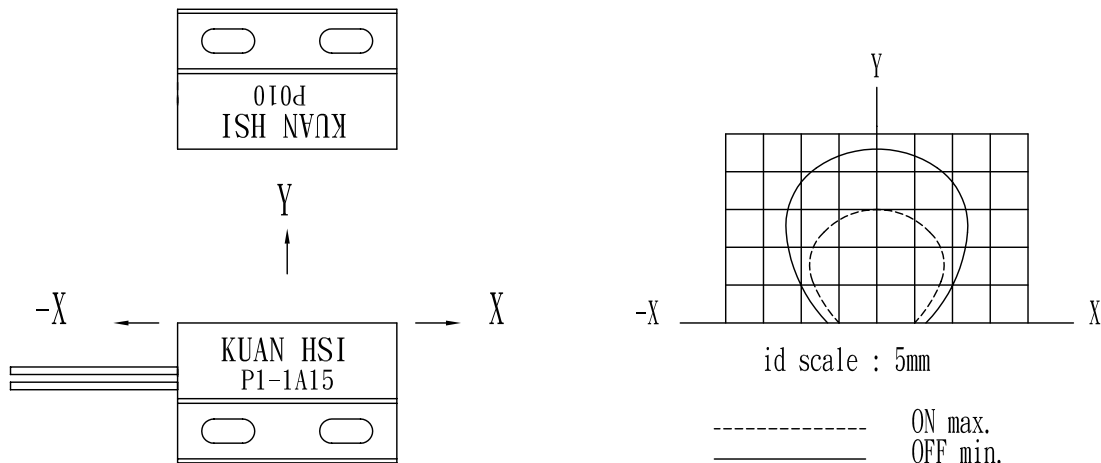

ISSUE	CHECK	APPROVED
-------	-------	----------